

TUBULAR FRAME CONSTRUCTION WTR I FOR HEAVY AND BIG COMPONENTS WORKPIECE CARRIER

This workpiece carrier is perfectly suitable for the automatised production of high-precision and delicate components. The deposit elements (metal/plastic) are adapted to the product to be carried. The workpiece carrier can be made of steel, stainless steel, aluminium or of a combinaton of these materials.

Workpiece carriers are produced undividually and based on the geometric form of the components to be carried. In the last 40 years BLOKSMA has developed more than 2400 different types of workpiece carriers.

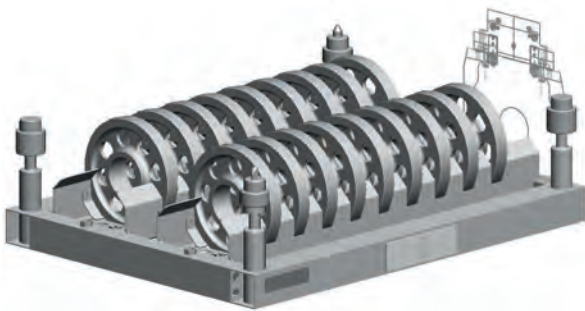

Item no. 133881

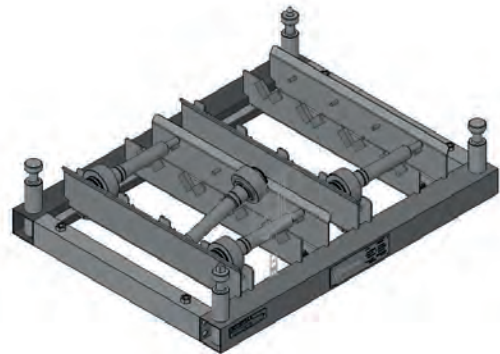

Item no. 131703

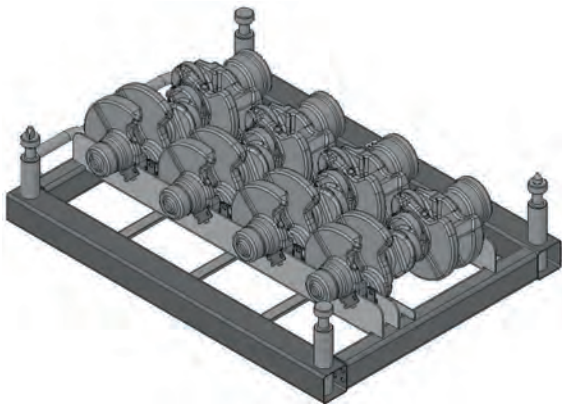

Item no. 142802

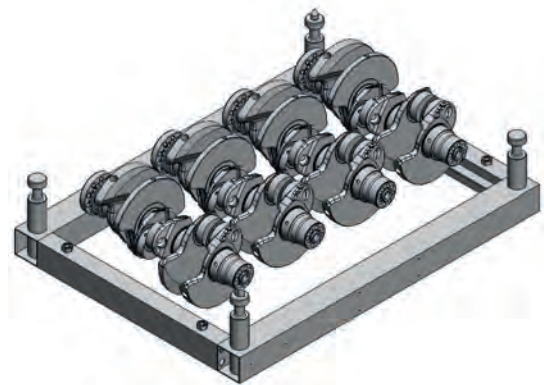

Item no. 141595

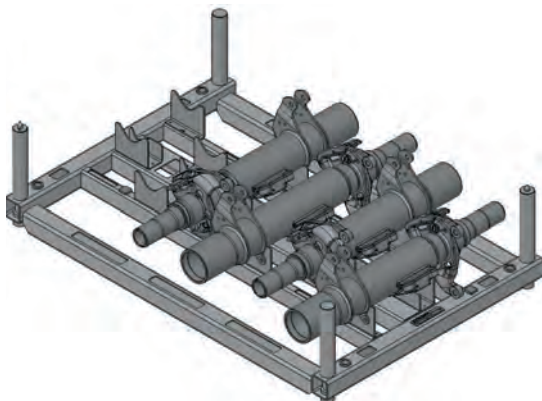

Item no. 128285

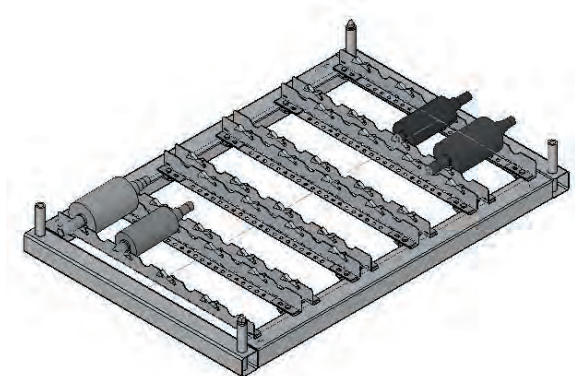

Item no. 131587

Other models / dimensions on request
Subject to technical changes

TUBULAR FRAME CONSTRUCTION WTR II FOR BIG AND HEAVY COMPONENTS WORKPIECE CARRIER

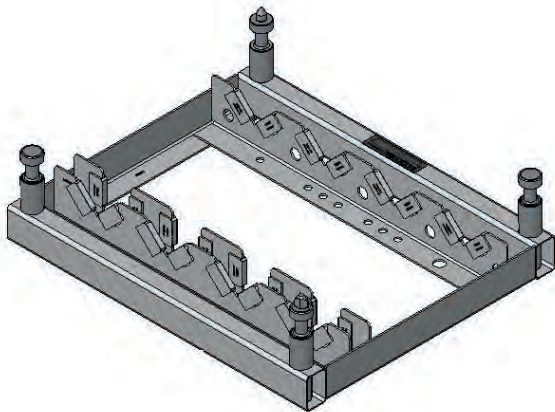

Item no. 131751

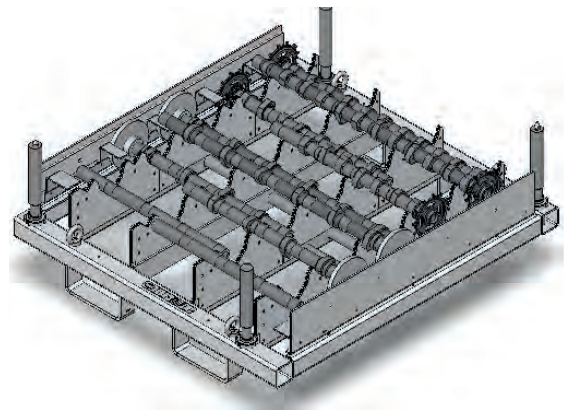

Item no. 132719

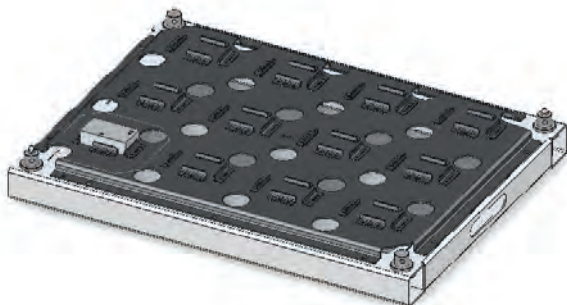

Item no. 126708

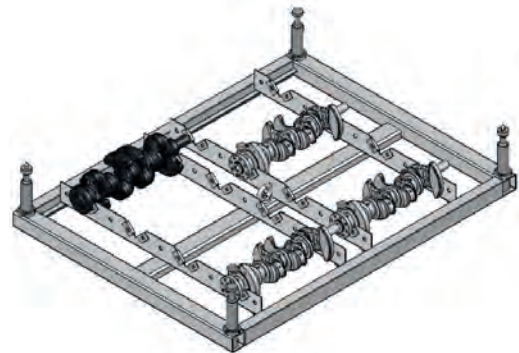

Item no. 133904

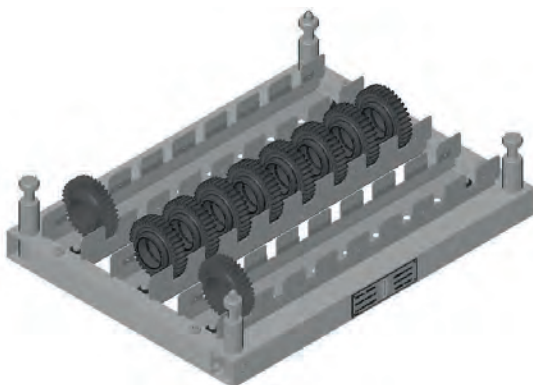

Item no. 139824

Other models / dimensions on request
Subject to technical changes